

CHAINS FOR SPECIAL APPLICATIONS – CANNING INDUSTRY

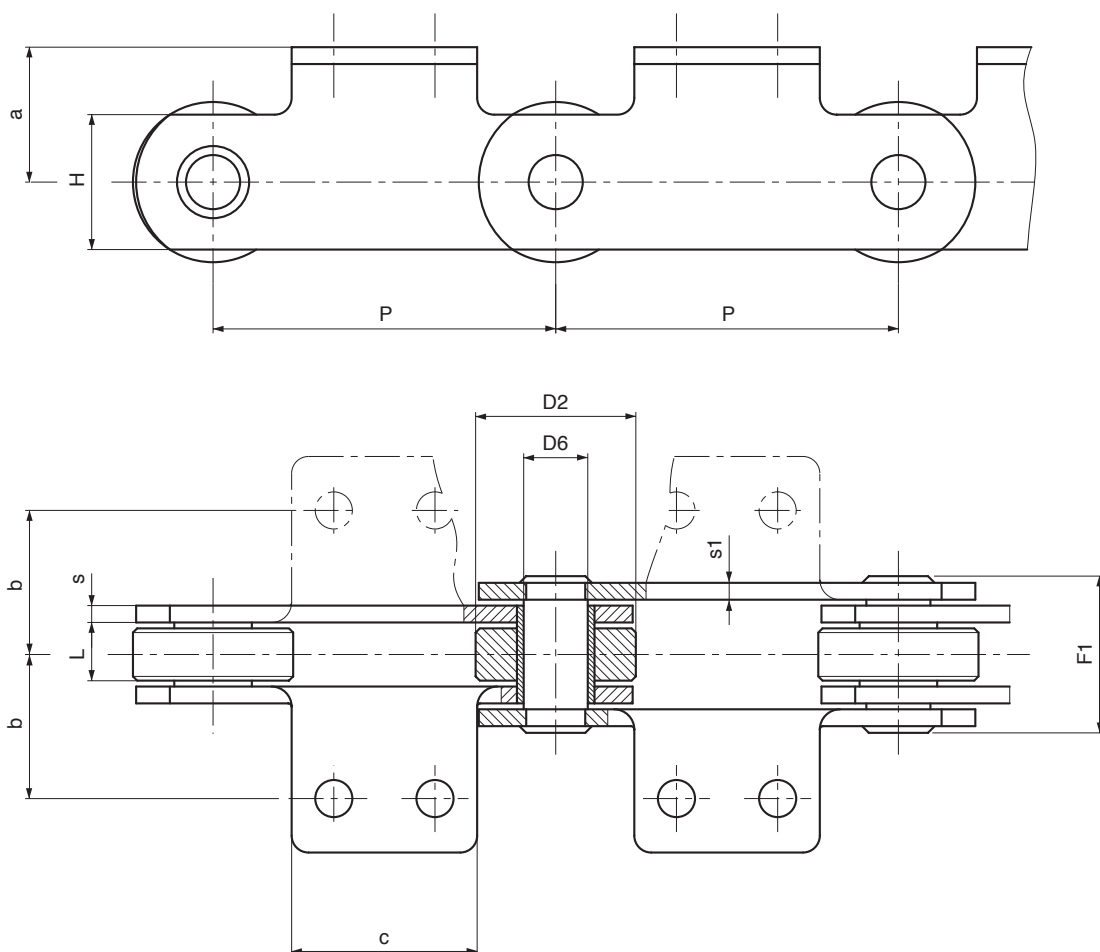

SOLID PIN CHAINS

Chain N.	P mm	L mm	D2 mm	D6 mm	H mm	S/S1 mm	a mm	b mm	c mm	F1 mm	Breaking load N
W2689	50	15	31	10	25	4/4	17,5	34	60	36	65.000
500BRA102	50	15	31	10	25	4/4	17,5	34	60	36	65.000
W4216	76,2	15	31,75	14	26,5	4/4	19	38,1	43	37	34.000
W1829	86	14,5	45	14	35	4/4	7,5	37	35	36,5	74.000
W1826	100	15	45	10	25	4/4	15	47,5	70	36	45.000
W4338	100	22	45	12	35	4/4	33,5	40	70	43	100.000
W3776	101,6	19	47,5	19	40	5/4	38	44,5	63,5	44,8	100.000
W3952	101,6	19	47,5	19	40	5/4	30	44,5	63,5	44,8	100.000
W2554/5	101,6	19	47,5	19	40	5/4	40	41	63,5	44,8	100.000

CHAINS FOR SPECIAL APPLICATIONS – CANNING INDUSTRY

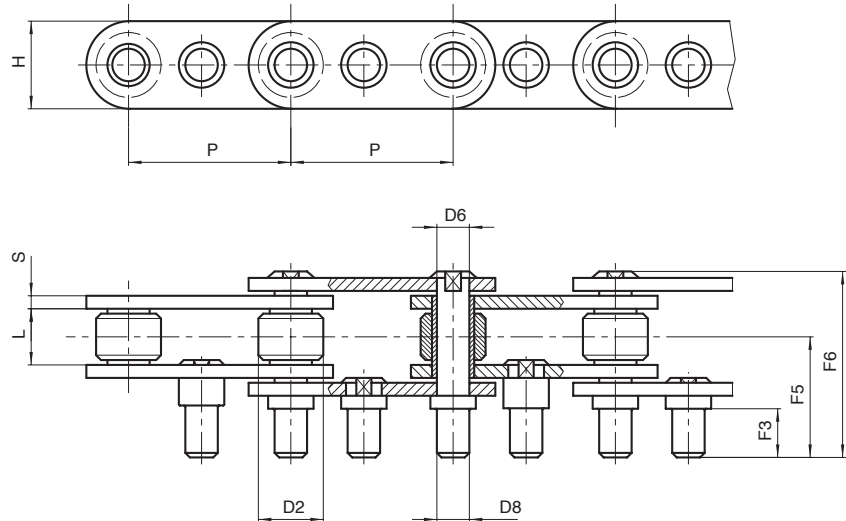

PEEL SEPARATORS

Chain N.	P mm	L mm	D2 mm	D6 mm	D8 mm	H mm	S mm	F3 mm	F5 mm	F6 mm	Breaking load N
W1173	50	15	20	9,85	10	27	4	15	32,5	53,5	75.000
W2938	50	15	20	9,85	10	25	4	15	32,5	57	70.000
W1440	53	16	27	8	8	20	3	17	32,5	53,5	24.000
W1527	53	16	25	8	8	20	3	15	32,5	53,5	50.000

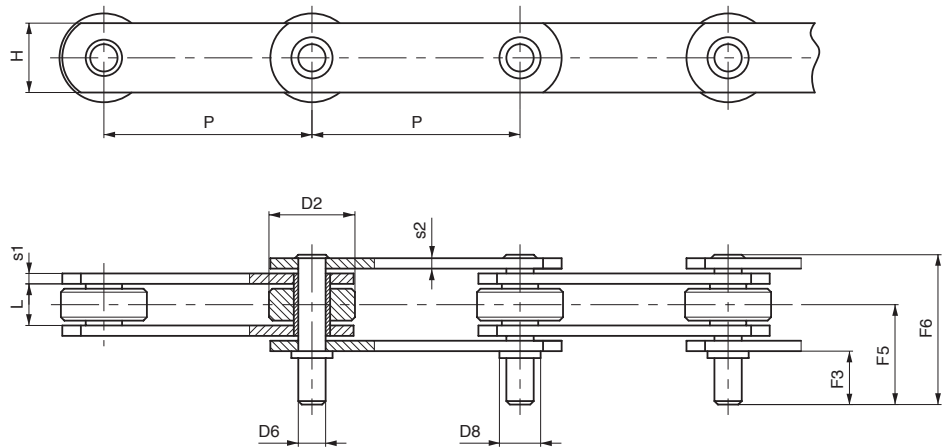

WITH EXTENDED PINS

Chain N.	P mm	L mm	D2 mm	D6 mm	D8 mm	H mm	S1/S2 mm	F3 mm	F5 mm	F6 mm	Breaking load N
500D202*	50	15	31	12	16	25	4/4	32	48	66	45.000
W1201	75	15	31	9,85	9,85	25	4/4	20	36	54	75.000
W1200	80	15	31	9,85	9,85	25	4/4	20	36	54	75.000
W2026	88,9	15	31,75	9,85	9,85	25	4/4	20	36	53,5	45.000
W1746	88,9	19	47,5	19,1	/	40	5/4	25	44,2	65,5	100.000
W2832	100	15	32	9,85	15	25	4/4	20	36	53,5	45.000
W1137	101,6	15	38	12	16	25	4/4	25	53,5	72	40.000

(*) Extended pins every 2 pitches

CHAINS FOR SPECIAL APPLICATIONS – CANNING INDUSTRY

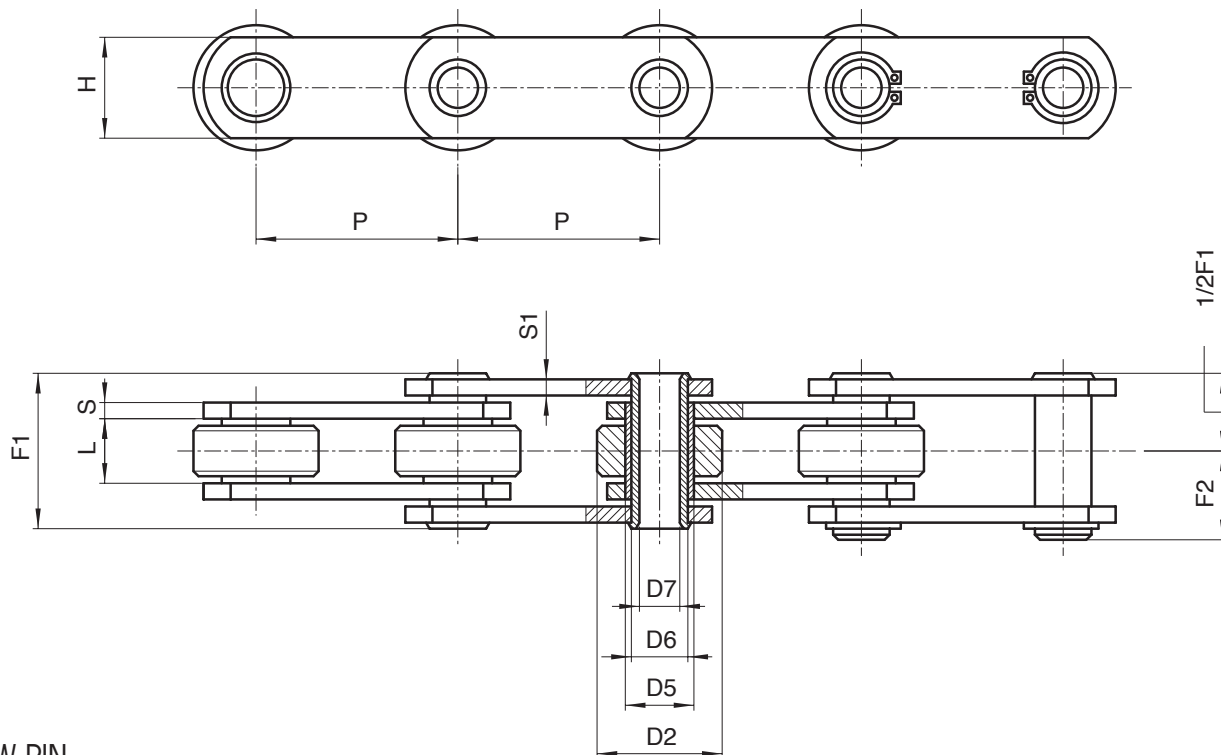

HOLLOW PIN CHAINS

Chain N.	P mm	L mm	D2 mm	D5 mm	D6 mm	D7 mm	H mm	S/S1 mm	F1 mm	Breaking load N
W2003*	50	11,5	25	11	9	6,2	20	2,5/2,5	25	25.000
W4886RZ@**	76,2	19	47,5	23	19	13,5	40	5/4	44,75	108.000
W1830	86	14,5	45	25	20	14,4	35	4/3	34	50.000
W2058	86	15	45	25	20	14,4	35	5/4	38,5	60.000
W3149	101,6	19	47,5	23,5	19	13,25	40	5/4	43,5	125.000
W2009	101,6	1 ³	47,5	23	18	13,5	40	5/4	43	60.000
W4890RZ@**	101,6	19	47,5	23	19	13,5	40	5/4	44,75	108.000
W4894RZ@**	127	19	47,5	23	19	13,5	40	5/4	44,75	108.000
W4769	127	19	47,5	23	19	13,5	40	5/4	44,75	69.000
W4962SS*	127	19	47,5	23	19	13,5	40	5/4	44,75	60.000

* STAINLESS steel chain
 ** zinc plated execution